

Scorpion & Scorpion T-10 Rifle Instructions

IMPORTANT: Please read these instructions and view the CD-ROM before first using your rifle.



www.bsaguns.co.uk

NUMBER OF SHOTS (Approx)

	Carbine	Fill Pressure
.177 (12 ft lbs)	50 shots	200 bar
.22 (12 ft lbs)	75 shots	200 bar
.177 FAC 18 ft lbs	20 shots	232 bar
.22 FAC 24 ft lbs	20 shots	232 bar



Gun Safety

- Make sure you know the laws relating to airguns, and abide by them.
- When you pick up any gun always check that it is not loaded.
- Never point a gun at anyone or anything that is not a legitimate target.
- Never leave your rifle unattended, even if it's unloaded.
- Gun safety is a state of mind; never rely on a safety catch.
- After use, put your rifle away safely; unloaded and out of reach of children. Store your pellets separately.
- Always ensure it is safe to shoot and be certain of your target before you squeeze the trigger.
- Make sure there is a safe backstop behind your target to catch your pellet in case you miss.
- Beware of ricochets – do not shoot at water or other smooth surfaces that may deflect the pellet in a different direction.
- Always unload your gun when crossing obstacles, taking it indoors or into a car.
- When carrying your rifle, be sure the muzzle is always pointing in a safe direction in case you should stumble.
- Never shoot on land without permission from the owner.

Technical Information

All BSA airguns are made to the highest standards at our factory in Birmingham. BSA barrels are cold hammer forged and crowned for optimum accuracy.

Before leaving the factory every airgun is tested on special purpose machinery to verify velocity and pellet grouping. UK law dictates that air rifles should not be capable of above 12 ft-lb of muzzle energy; all BSA models conform to this requirement. Export models are supplied to conform to the laws in the destination country.

Using Compressed Air

CAUTION!

Only dry breathing quality air should be used in guns.
Never fill any gun with oxygen, or any other gas.
Doing so could cause a serious explosion.

Never try to fill your gun with air when the rifle is in a partially assembled state.

The Scorpion can be filled from an air tank or using a hand pump. Whichever equipment is used, a pressure gauge and supply hose bleed device must be included, and the manufacturers' instructions must always be followed.

Telescopic Sights

The BSA Scorpion has a full length integral 10.8mm dovetailed scope rail designed to accept standard scope mounts and night vision equipment. Refer to the scope manufacturer's instructions on fitting and adjusting.

Filling the Rifle with Air

The maximum filling pressure for the Scorpion and Scorpion T-10 are shown in the table above. Do not over charge the rifle as this may be dangerous. Doing so will reduce the power and will damage the rifle.

A filling adaptor is supplied with each rifle; this has a restrictor screw fitted which must be screwed tightly in place when using an air tank to fill the gun, or the rifle could be damaged. If using a hand pump the restrictor screw should be loosened or removed using the Allen key provided

- Before filling always make sure the gun is not loaded.
- Unscrew the end cap from the front of the air reservoir.
- If the air reservoir is empty, cock the rifle
- Insert the filling adaptor into the filling port, and push it home.
- Make sure the bleed screw on the charging unit is closed, and then open the air bottle valve slowly.
- Slowly fill the gun to the maximum recommended charge pressure, and close the valve. Allow a few minutes for the pressure to settle, and then, if needed, top up the pressure in the gun, and close the valve again.
- Quickly open the bleed valve on the charging unit to allow the air in the hose to escape.
- Pull the filling adaptor from the filling port and replace the end cap.
- Remember that your rifle may be cocked, if so you should de-cock it immediately for safety reasons.
- To de-cock your rifle, pull back the bolt and while holding the bolt pull the trigger and slowly allow the bolt to move forward until it is back in the rest position.

Regularly check the condition of the filling probe "O" rings and apply a little Molycote 111 grease. Only use this grease on the "O" rings as automotive mineral oils and grease can cause an explosion if used with high-pressure air.

Loading the Single Shot Scorpion

- Make sure the safety catch is in the rear (safe) position.
- Lift the bolt handle and pull back until the bolt locks.
- With the bolt open, place a pellet in the loading port.
- Push the bolt forward to load the pellet into the breech, and down to return the bolt to its original position. The gun is now cocked and loaded.
- The gun can be de-cocked by pulling the bolt back, and while holding it firmly, squeezing the trigger to allow the bolt to move forward against resistance. Remember that there may still be a pellet in the barrel, and never store the gun loaded.

Loading the Scorpion T-10

- Apply the safety catch and remove the magazine from the gun by pushing the magazine retaining catch forward.
- Lift the bolt handle and pull back as far as it will go, and while holding the bolt right back, remove the magazine.
- Hold the magazine between finger and thumb with the cover plate screw uppermost. Push a pellet nose first into the first magazine chamber and press down until the pellet skirt is under the cover plate (see Fig 1).
- Rotate the central body of the magazine anti-clockwise until the next vacant position lines up with the hole in the cover plate. Insert another pellet and repeat the procedure until the magazine is full (see Fig 2).
- The red dot on the magazine body will be at the top when all ten pellets are loaded.
- At any stage during loading, the magazine body can be moved back one position by pressing the escapement mechanism lever (see Fig 3).
- Replace the magazine in the rifle (see Fig 4) and push the retaining catch back to lock the magazine in place, slide the bolt forward and down into the retaining slot and take off the safety catch. The rifle is now ready to fire.
- When the tenth and final pellet has been indexed into position, a red spot indicator on the magazine body will come into view when the bolt is pulled backwards to cock the rifle. Lock down the bolt in the forward position to fire the last shot.

Note: The magazine is factory filled with lubricating grease. Take care to avoid contamination with dirt or grit and always carry magazines in a sealed plastic bag. Do not take the magazines to pieces, or remove this grease.



Trigger Adjustment

Always ensure that your gun is not cocked or loaded before adjusting the trigger. In the interests of safety, take care not to over-lighten the trigger weight.

The trigger is set at the factory, but some aspects can be adjusted to suit individual preferences.

1. Trigger pull. This screw adjusts the weight of second stage trigger pull, to increase the weight of pull turn the screw clockwise and anti-clockwise to reduce the weight of pull.

2. Sear engagement screw. This screw determines the length of the second stage release. Should you wish to adjust the length of the second stage release, slacken off the locknut and adjust the screw the desired amount. Turning the screw clockwise reduces the second stage release; turning it clockwise increases the second stage release.

CAUTION GREAT CARE SHOULD BE TAKEN IN THE ADJUSTMENT OF THIS SCREW. ANY EXCESSIVE CLOCKWISE TURN COULD RENDER THE GUN IN A CONDITION IN WHICH IT COULD FIRE ACCIDENTALLY. IF IN ANY DOUBT CONSULT A QUALIFIED GUNSMITH

3. First stage trigger adjustment, this is factory preset and must not be adjusted.

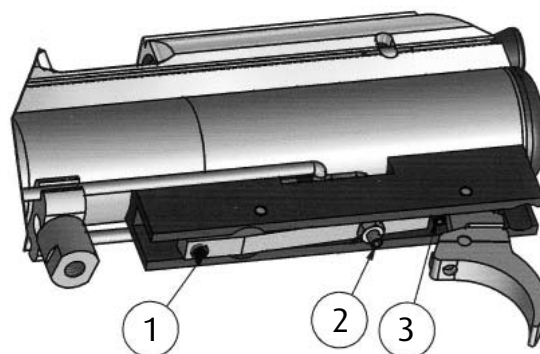

Care and Maintenance

After use, check that your rifle is unloaded and wipe the metal and woodwork surfaces with a lightly oiled cloth. Pay special attention to the metal finishes as these are not fully rustproof and are vulnerable to damp and particularly perspiration. If your rifle has become damp, make sure it is completely dry before you put it away.

Never use oils containing SILICON as they can cause damage to metal surfaces. Application of oil and grease except as directed by the manufacturer can often do more harm than good.

Your rifle has been designed and manufactured for optimum performance. Tampering with the components, or unauthorised modifications and alterations may make the rifle unsafe to use and will invalidate the warranty. All air rifles require periodic maintenance and inspection, so even if everything seems to be in good working order, have your air rifle checked periodically by a competent gunsmith. You should always have the power of your air rifle re-checked following any maintenance or repair work as any repairs or adjustments could affect

the power. **It is your legal responsibility to make sure the air rifle remains below the legal limit, which in the UK is 12 ft-lb.**

The rifle's air reservoir must always be kept in good condition. If any damage occurs, for example, denting, exposure to extreme temperatures or rust, the gun should be inspected by the manufacturer, or their appointed agent. The internal bore of the air cylinder must be inspected for corrosion periodically; which should not exceed 5 year intervals.

Diagrams and parts lists are available on our website at www.bsaguns.co.uk

2 Year Warranty

All new BSA rifles carry a 2 year warranty against faulty parts and labour, this applies to new rifles only and is not transferable; proof of purchase is required. Excluded from this warranty are: failure due to misuse or abuse, the fitting of non-standard parts, and fair wear and tear. All warranty work must be done by BSA or an authorised agent of the company, and should the rifle be collected or returned under warranty, BSA or their authorised agent reserve the right to charge for postage and / or inspection.